

## Grade 10 Applied Exam Review

### Unit 1 - Similar Triangles

1. **CONVERT** the following measures as indicated. Show how you converted by including the numbers that you used to divide or multiply.

a) 2.5 cups to quarts

b) 5 pints to fl ounces

c) 4 gallon to pints

d) 64 ounces to pounds

e) 3 quarts to gallons

f) 2 gallon to cups

g) 2 miles to kilometres

h) 3 feet to inches

i) 3 centimetres to inches

j) 5 cu cm to inches<sup>3</sup>

k) 10 ounces to grams

l) 1 mile to kilometres

2. **CONVERT** each of the following areas to square yards.

a) 5' 2" by 7' 3"

b) 5.2m by 6.3m

3. A field measures 146' by 189'. Find the length of fence in metres needed to surround the field.

4. Given the following similar triangles ABC and XYZ, list the corresponding sides and angles.

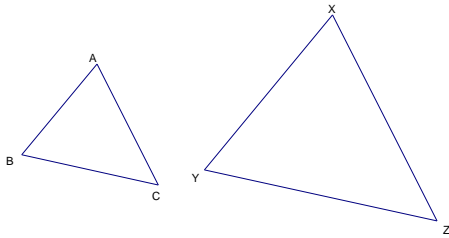

5. Kerri's bedroom needs new carpet. Her room measures 11' 4" by 12' 6". The new carpet costs \$22.95 per square yard. How much does it cost for new carpet?

6. Brad needs to paint his garage. The floor plan of the garage and measurements are given. The garage door wall will NOT be painted. All walls are 8' high.

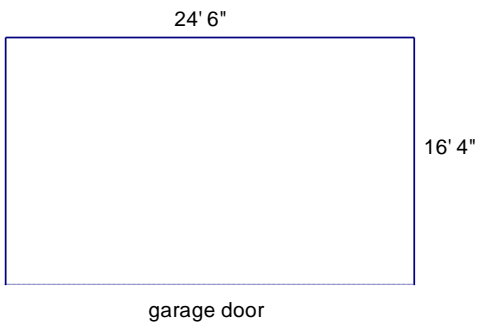

- a) How much surface area (in square yards) needs paint?
- b) If one can of paint covers  $25\text{m}^2$  of space, how many cans are needed?

7. Given the following similar triangles, find the missing side or angle as indicated.

a)  $\triangle ABC \sim \triangle DEC$

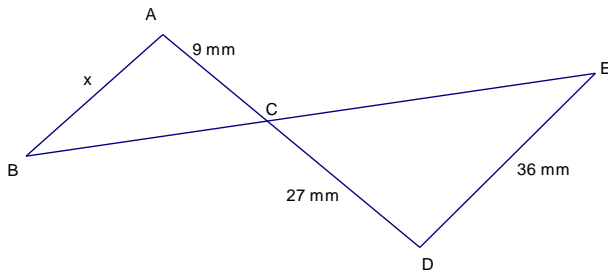

b)  $\triangle DEF \sim \triangle PQR$

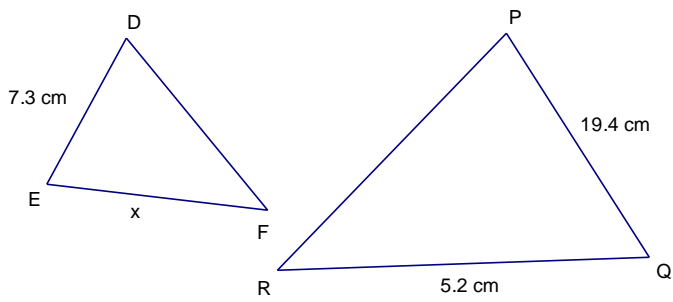

## Unit 2 - Right Angle Trig

Formulas: SOH CAH TOA

$$c^2 = a^2 + b^2$$

1. Label the sides of the following triangles using *opposite*, *adjacent*, or *hypotenuse* with respect to angle  $x$ .

a)

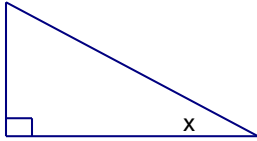

b)

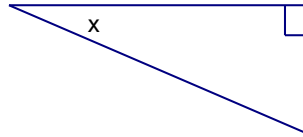

2. Determine which ratio you would use to solve for the unknown. *You DO NOT need to solve.*

a)

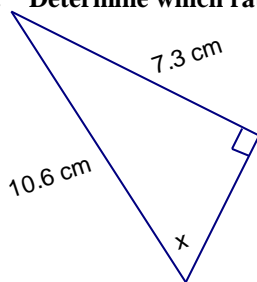

b)

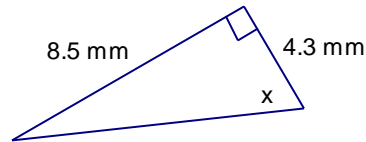

c)

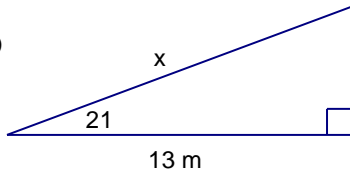

d)

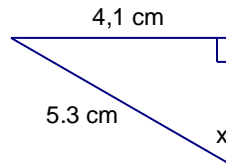

3. Given the following triangle, write the required ratios in both fraction and decimal form. Round your decimals to the nearest four decimal places.

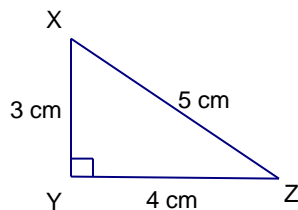

	Fraction	Decimal
$\sin X =$	_____	_____
$\cos X =$	_____	_____
$\tan X =$	_____	_____

	Fraction	Decimal
$\sin Z =$	_____	_____
$\cos Z =$	_____	_____
$\tan Z =$	_____	_____

4. Use your calculator to write the decimal approximation to the nearest four decimal places.

a)  $\sin 45 =$  \_\_\_\_\_ b)  $\cos 36 =$  \_\_\_\_\_ c)  $\tan 74 =$  \_\_\_\_\_

5. Use your calculator and inverse trig function to find the angle to the nearest degree. (1 mark each)

a)  $\sin A = 0.9511$       b)  $\cos B = 0.4540$       c)  $\tan C = 1.1504$   
 $A =$  \_\_\_\_\_       $B =$  \_\_\_\_\_       $C =$  \_\_\_\_\_

6. Solve for each unknown. Show your work in an organized manner.

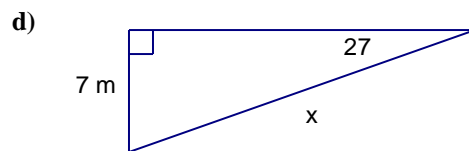
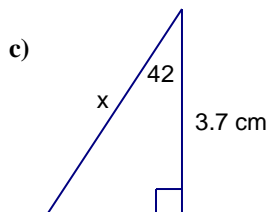
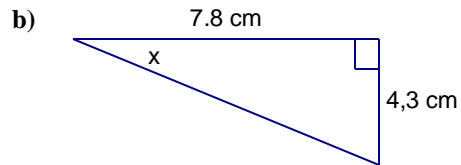
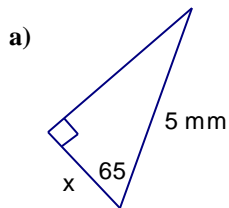

e)

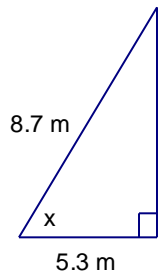

f)

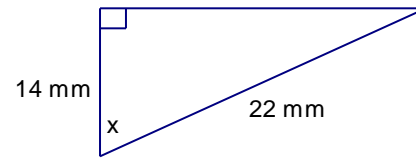

7. Devon finds the following information about a bridge and records it in the given diagram. How high is the bridge?

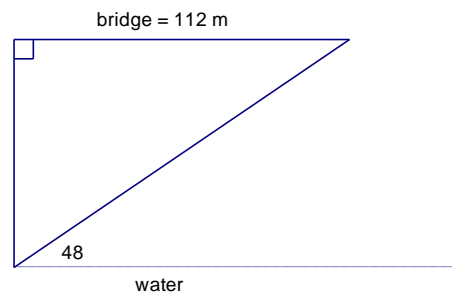

8. George leans a ladder against a tree to rescue an injured cat. The ladder is 4 m in length and he places it at an angle of 65 degrees. The cat is 5.5 metres high in the tree.

a) Draw a diagram that represents this information.

b) **Can George reach the cat? Show your work.**

c) **How far is the ladder from the tree? Show your work.**

9. **A man wants to know the height of a very tall building. From the top of a smaller building he can see the top of the tall building at an angle of inclination of 33 degrees. From the top of the smaller building he can also see the bottom of the tall building at an angle of depression of 52 degrees. If the buildings are 25 m apart,**

a) **Draw a diagram that represents this information.**

b) **Solve for the height of the tall building being careful to show your work in an organized manner.**

- 10. Megan wants to know how long her shadow is when the sun is at an angle of inclination of 75 degrees.  
If Megan is 1.8 m tall,**
- a) **Draw a diagram representing this information.**

- b) **How long is the shadow?**



## Unit 3 - Linear Relations

1. Match the word and definition by placing **LETTER** in the space provided.

**A** – a relation between two variables that appears as a straight line when graphed

**B** – the vertical change between two pairs of points

**C** – the horizontal change between two pairs of points

**D** – a line with a slope of zero

**E** – characteristic of slopes of parallel lines

**F** – the steepness of a line

**G** - slope

**H** – direction of line with positive slope

**I** - direction of line with negative slope

**J** – the first difference of a linear relation

run \_\_\_\_\_

slope \_\_\_\_\_

rise \_\_\_\_\_

up to the right \_\_\_\_\_

down to the right \_\_\_\_\_

linear \_\_\_\_\_

constant \_\_\_\_\_

rate of change \_\_\_\_\_

equal \_\_\_\_\_

flat/horizontal \_\_\_\_\_

2. From the graph provided, write the y-intercept, the slope and the equation of the line.

a)

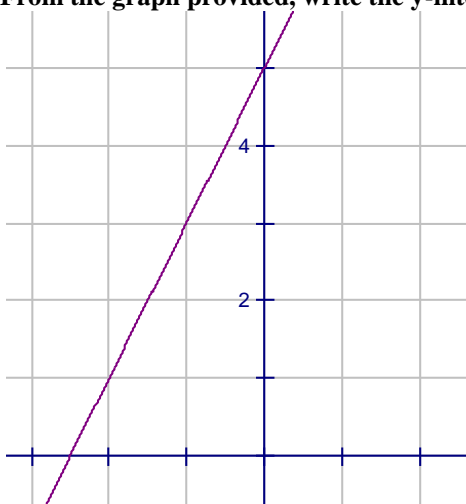

slope: \_\_\_\_\_

y-intercept: \_\_\_\_\_

equation: \_\_\_\_\_

b)

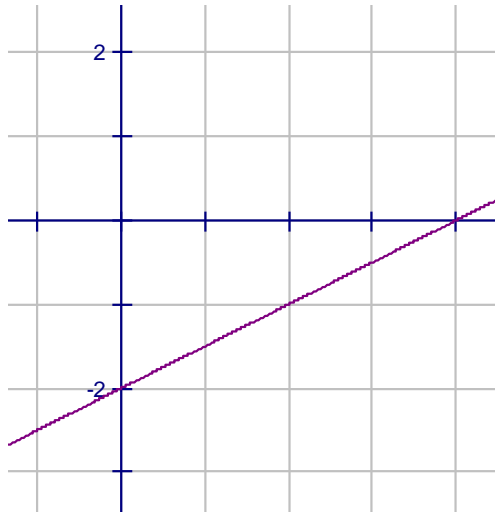

slope: \_\_\_\_\_

y-intercept: \_\_\_\_\_

equation: \_\_\_\_\_

3. Complete the following table by indicating the value of the slope, the y-intercept or writing the equation.

Equation	Slope	Y - intercept
$y = 7x - 1$		
	2	9
$y = -2x$		
$y = -5$		
	$\frac{5}{6}$	7
$y = \frac{-3}{5}x + 2$		
	-4	10
$y = x - 2$		
$y = -x + 3$		

4. Complete the table and graph the line on the grid provided. (4 marks each)

a)  $y = -3x + 1$

x	y
0	
1	
2	
3	
4	

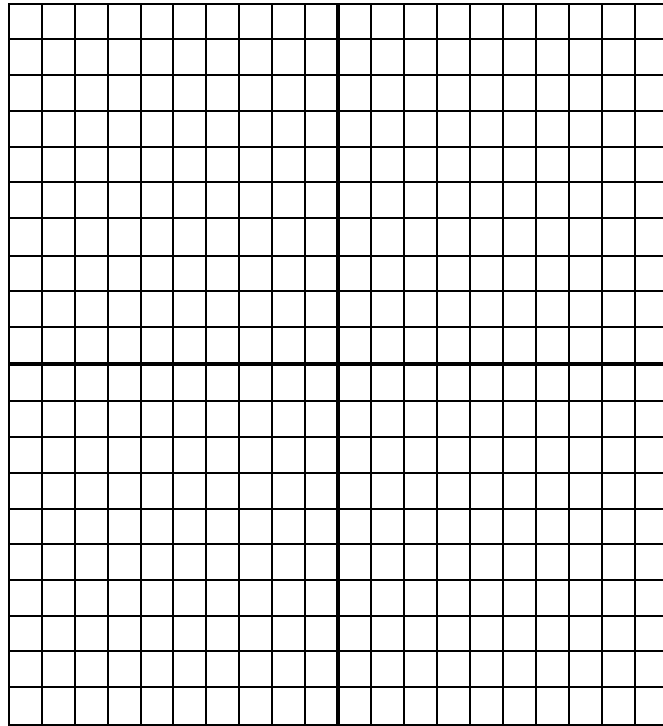

b)  $y = \frac{1}{2}x + 8$

x	y
0	
2	
4	
6	
8	

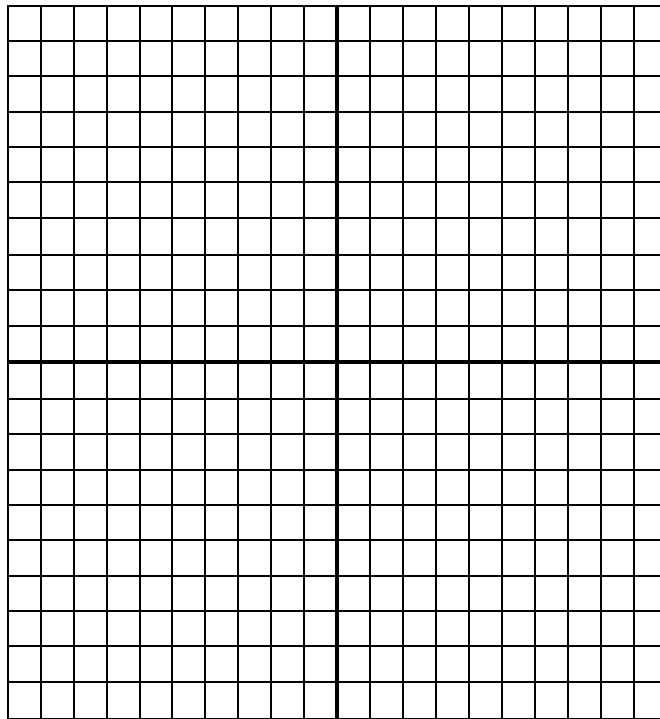

5. Given the following information, write the equation of the line described. (2 marks each)
- a) Bonnie is paid \$25 per hour for every dog she walks plus \$30 for her exercise plan.
- b) David delivers papers for the local news. He is paid \$18 plus \$0.35 per paper.
- c) The local restaurant pays their employees a base wage of \$125 plus tips of \$7 per customer.
- d) An insurance company charges the local business \$1250 plus \$75 per employee.
6. Write the equation given the following information for each line. Be sure to show your work! (3 marks each)
- a)  $m = 2$ , and the point  $A(4, -1)$
- b)  $m = -1$ , and the point  $B(-2, 7)$

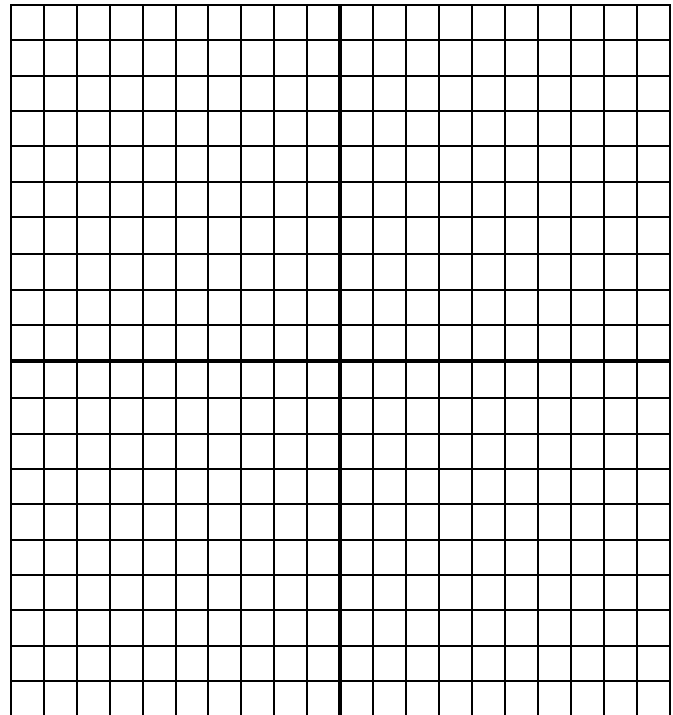

7. Determine the equation of the line passing through the given points. (You may use the grid at the bottom of the page to explore the slope if necessary.) (4 marks each)

a)  $A(-1, -5)$  and  $B(0, 2)$

b)  $C(2, 3)$  and  $D(1, 6)$

**Unit 4 – Linear Equations**

1. Solve each equation for the unknown variable.

a)  $2x + 5 = 7$

b)  $8 - t = 10$

c)  $\frac{3x+4}{2} = 5$

d)  $6(x-2) = 3x$

e)  $3(y+1) = 2(y-3)$

f)  $\frac{x+6}{3} = 2 + \frac{x-2}{5}$

**2. Rearrange each equation into  $y = mx + b$  form.**

a)  $2x + y - 3 = 0$

b)  $2x + 3y - 12 = 0$

**3. Rearrange each formula for the indicated variable.**

a)  $P = 2a + b$  solve for  $a$

b)  $A = P + Prt$  solve for  $r$

## Unit 5 – Solving Linear Systems

1. Match each of the following terms by placing the LETTER of each definition by the correct word.

- |   |                              |
|---|------------------------------|
| A. a set of two or more linear relations  | point of intersection _____  |
| B. the graphical solution to a linear system  | elimination method _____     |
| C. the point at which the cost to produce an item is equal to the selling price         | graphical intersection _____ |
| D. an algebraic method to solve a linear system   | substitution _____           |
| E. a graphical method to solve a linear system  | linear system _____          |
| F. an method of solving a linear system when one variable is eliminated from the system | breakeven point _____        |

2. Solve each of the following systems by GRAPHING. Clearly indicate your point of intersection.

a)  $y = 3x + 5$  and  $y = -3x - 1$

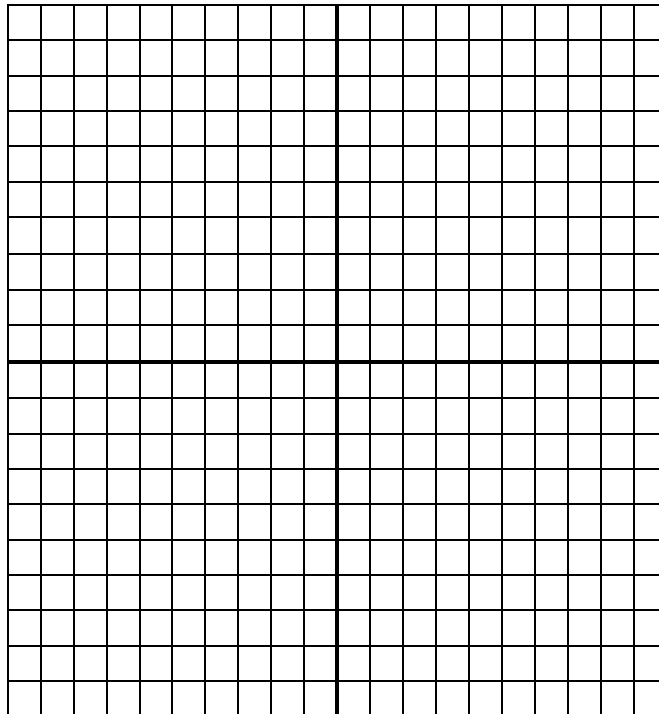



b)  $y = \frac{1}{2}x - 1$  and  $y = -x + 2$

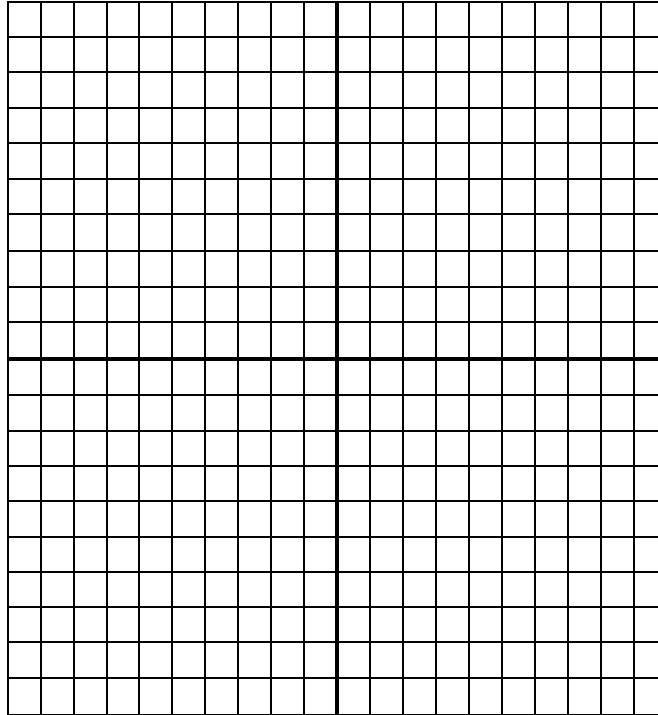

3. Solve this system using substitution.

$$y = -2x - 4$$

$$-6x + 8y = -10$$

4. **Solve this system using elimination.**

$$2x + 4y = 6$$

$$-3x - 4y = -1$$

5. **The difference of two numbers is 2. Their sum is 12. What are then numbers?**

6. **The water park is a popular field trip destination. Falls High filled 2 vans and 9 buses with 383 students. Rainy High filled 8 vans and 3 buses with 179 students. Find the number of students in each van and each bus.**

7. Gary and Jamie are selling chips and pop to support their school trip. Gary sells 5 cases of pop and 13 cases of chips for \$238. Jamie sells 14 cases of pop and 14 cases of chips for \$308. Find the cost of each case of pop and chips.
8. Mikaela and Ted each improved their yards by planting shrubs and sod. Mikaela spent \$228 on 4 ft<sup>2</sup> of grass sod and 15 shrubs. Ted spent \$204 on 10 ft<sup>2</sup> of grass sod and 7 shrubs. Find the cost of one ft<sup>2</sup> of grass sod and one shrub.

## Unit 6 - Quadratic Relations

1. Match the correct word with the correct definition by placing the LETTER in the space provided

- |   |                          |
|---|--------------------------|
| A. the point at which the parabola changes direction            | coefficient of 'a' _____ |
| B. a symmetrical u-shaped graph                                 | x-intercepts _____       |
| C. calculate these to determine whether a relation is quadratic | quadratic relation _____ |
| D. points where the graph crosses the x-axis                    | second differences _____ |
| E. a vertical line that passes through the vertex               | parabola _____           |
| F. an equation that describes a parabola                        | first differences _____  |
| G. point where the graph crosses the y-axis                     | y-value of vertex _____  |
| H. direction of opening is determined by this                   | axis of symmetry _____   |
| I. calculate these to determine whether a relation is linear    | y-intercept _____        |
| J. the maximum or minimum value                                 | vertex _____             |

2. Graph each of the following quadratic relations by completing the table of values.

a)  $y = -2(x + 2)^2 + 5$

x	y
-4	
-3	
-2	
-1	
0	
1	

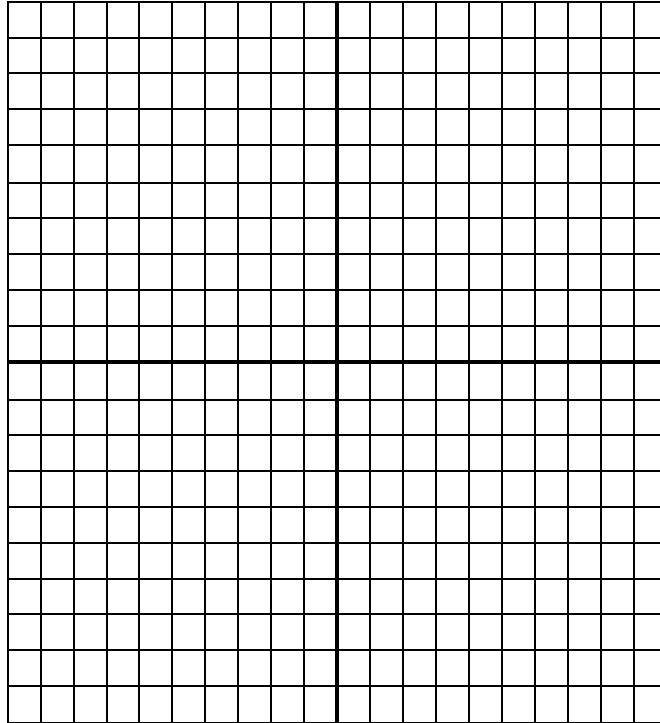

b)  $y = x^2 - 2x - 1$

x	y
-1	
0	
1	
2	
3	
4	

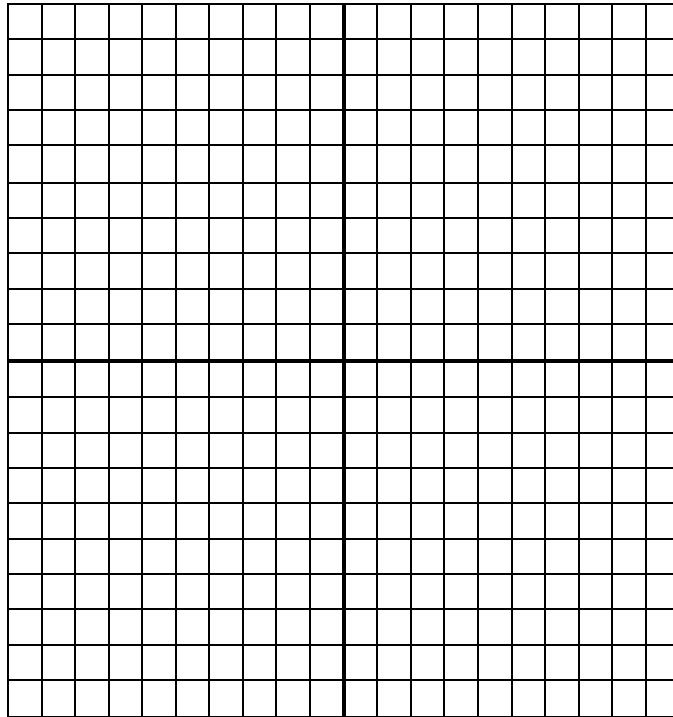

3. Determine whether each relation is linear, quadratic, or non-linear. How do you know? Include a REASON as part of your answer.

a)  $y = x^2 + 5x - 2$

b)

x	y
-2	-4
-1	-1
0	0
1	-2
2	-4

c)

x	y
-2	9
-1	5
0	2
1	0
2	-1

d)  $y = -3x^3 + 4x^2 - x + 5$

4. For each of the following, identify the information asked.

a)

x-intercepts: \_\_\_\_\_

y-intercept: \_\_\_\_\_

vertex: \_\_\_\_\_

equation of axis of symmetry: \_\_\_\_\_

state max or min: \_\_\_\_\_

max or min value: \_\_\_\_\_

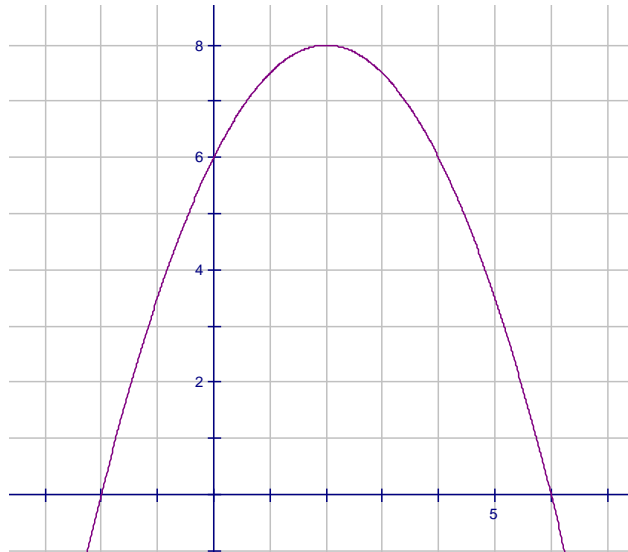

5. Trainers recognize that dolphins jump in parabolic arches. If an axis is imposed over the arch according to real life scale, identify each of the following. (6 marks)

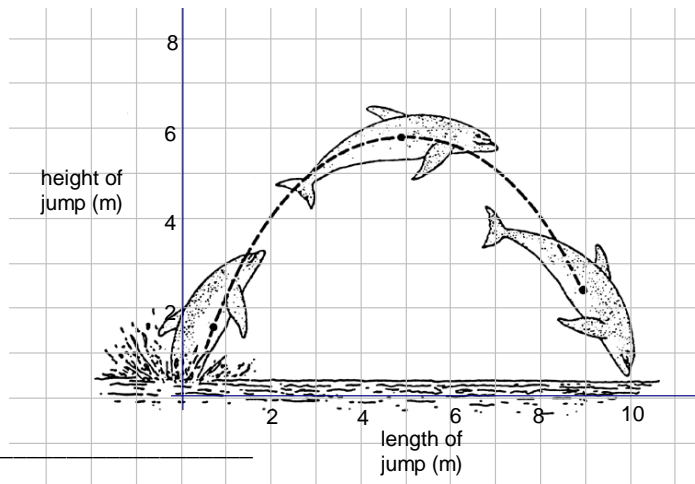

x-intercepts: \_\_\_\_\_

y-intercept: \_\_\_\_\_

vertex: \_\_\_\_\_

equation of axis of symmetry: \_\_\_\_\_

state max or min: \_\_\_\_\_

max or min value: \_\_\_\_\_

If we write the vertex  $(g, h)$  from this diagram into the equation  $y = a(x - g)^2 + h$  (called the vertex form of the quadratic relation), we can get an equation for this parabola.

**Step 1:** replace your numbers for the vertex into the formula

$$y = a ( x - \underline{\hspace{2cm}} )^2 + \underline{\hspace{2cm}}$$

**Step 2:** if we substitute  $(0, 0)$  for  $x$  and  $y$  in your formula

$$0 = a ( 0 - \underline{\hspace{2cm}} )^2 + \underline{\hspace{2cm}}$$

**Step 3:** using your work from above, solve your equation for the value of 'a'

**Step 4:** put all three values for  $a$ ,  $g$ , and  $h$  back into the original  $y = a(x - g)^2 + h$  to write the formula for the dolphin parabola.

## Unit 7 - Quadratic Expressions

1. Match the correct word to its definition.

- |   |                                |
|---|--------------------------------|
| A. the result of squaring a binomial                  | foil _____                     |
| B. an algebraic expression with two terms             | coefficient _____              |
| C. an algebraic expression with three terms           | GCF _____                      |
| D. any algebraic expression                           | factoring _____                |
| E. the opposite of expanding                          | perfect square trinomial _____ |
| F. the biggest number common to two or more monomials | polynomial _____               |
| G. the term for the number of a monomial              | variable _____                 |
| H. the term for a letter in a monomial                | binomial _____                 |
| I. to multiply using the distributive property        | expand _____                   |
| J. first, inner, outer, last                          | trinomial _____                |



2. Expand and simplify each of the following using FOIL.

a)  $(x+3)(x-2) =$

b)  $(2x-3)^2 =$

3. Common factor each of the following.

a)  $3x^2 + 6x =$

b)  $-2x^2 + 6x - 4 =$

4. Simplify each monomial completely using the given exponent rules. Be sure to use your rules FIRST in order to receive full marks. (15 marks)

To multiply terms, keep the base and ADD the exponents

To divide terms, keep the base and SUBTRACT the exponents

To use power of a power, keep the base and MULTIPLY the exponents

To simplify a zero exponent, anything to the exponent zero is ONE

To simplify a negative exponents, use the RECIPROCAL

a)  $2^3(2^4) =$

e)  $(3^2)^2 =$

b)  $x^7(x^3) =$

f)  $(x^5)^{11} =$

c)  $\frac{5^7}{5^4} =$

g)  $4^0 =$

d)  $\frac{x^{12}}{x^{10}} =$

h)  $x^0 =$

i)  $2^{-3} =$

j)  $x^{-5} =$

5. Complete the following chart.

Product	Sum	Two Integers
14	9	
24	11	
-21	-4	
-12	-11	
-64	0	
-9	0	
-30	-7	
12	-8	
22	-13	
5	-6	

6. Factor each of the following difference of squares.

a)  $x^2 - 121 =$

b)  $x^2 - 64 =$

c)  $9x^2 - 100 =$

d)  $25x^2 - 16 =$

7. Factor each of the following trinomials.

a)  $x^2 + 3x + 2 =$

b)  $x^2 + 3x - 28 =$

c)  $x^2 - 4x - 12 =$

d)  $x^2 - 6x + 9 =$

8. Find an expression for the shaded area of the given rectangle.

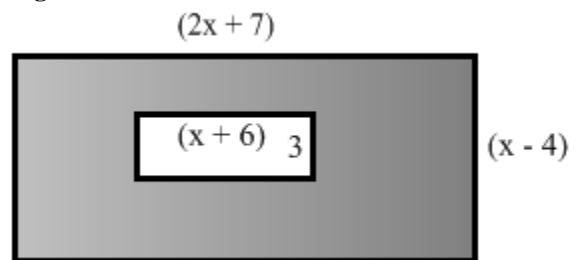

9. A large rectangular field has an area of  $(121x^2 + 55x)$ .

a) Find expressions for the dimensions of the rectangle.

b) If  $x = 2m$ , find the actual dimensions of the rectangular field.

10. The area of a television screen is represented by the expression  $(x^2 - 5x - 14)$ . Find expressions for the length and width of the screen.

**Unit 8 – Representing Quadratic Relations**

1. Find the  $y$  – intercept, the zeroes ( $x$  – intercepts), and the maximum or minimum value.

a)  $y = -x^2 + 36$

b)  $y = -2x^2 + 8$

c)  $y = 3x^2 + 9x$

d)  $y = x^2 + 3x - 18$

2. Factor each of the following. Be sure to observe the difference between the need for one bracket as in common factoring, the need for two brackets as in difference of squares or trinomials, or the need for a combination of both.

a)  $-4x^2 + 8x =$

b)  $6x^2 + 24x =$

c)  $x^2 - 49 =$

d)  $9x^2 - 64 =$

e)  $x^2 + 4x - 12 =$

f)  $x^2 - 6x + 9 =$

g)  $5x^2 + 15x - 90 =$

h)  $-2x^2 + 4x + 126 =$

3. Given each table of values, graphs the relation and find the equation of each quadratic.

a)

x	y
0	-1
1	4
2	7
3	8
4	7
5	4
6	-1

b)

x	y
0	-1
1	-4
2	-5
3	-4
4	-1
5	4
6	11

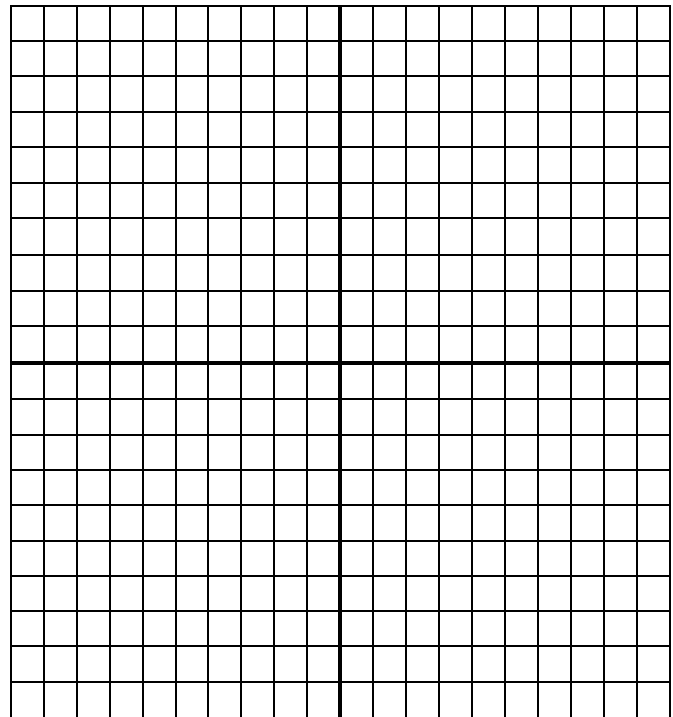
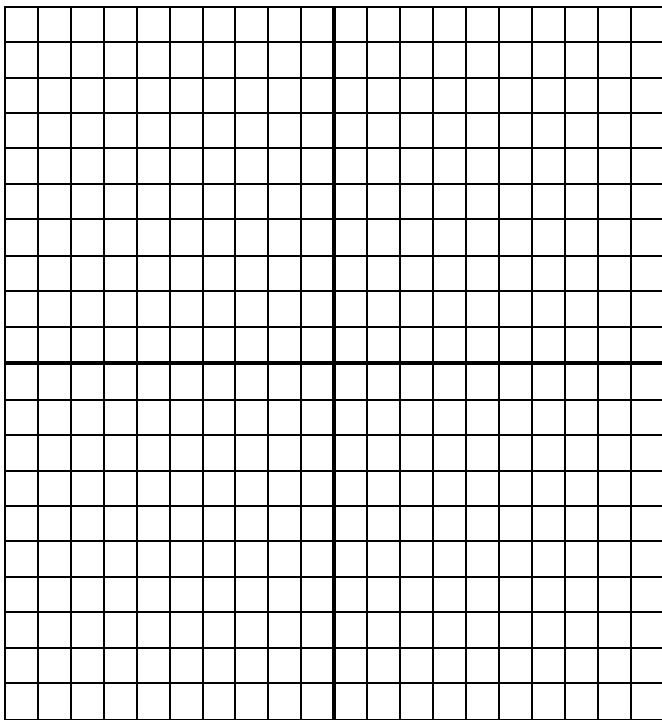

- 4. At a car show, Evil Kineval jumps his car over several other parked cars. His flight path can be modeled by the equation  $y = -0.25x^2 + 1.75x - 1.5$ . The variable  $x$  represents seconds the car is in flight and the variable  $y$  represents the height of the car.**
- a) What is the height of the ramp that Evil Kineval's car flies from?
  
  - b) What is the maximum height that Evil Kineval's car reaches?
  
  - c) When does Evil Kineval reach his maximum height?
  
  - d) How high above the ground is Evil Kineval after 4 seconds?
  
  - e) How long does it take Evil Kineval to hit the ground?

5. A valley can be modeled by the equation  $y = 0.2x^2 - 0.2x - 2.4$ . The zeroes of this equation represent a bridge that can be used to pass over the valley. The  $x$  variable represents the distance someone must walk to cover the bridge and the  $y$  variable represents the depth of the valley.
- a) How wide is the valley?
- b) How deep is the valley?
- c) If someone was to walk down into the valley, how far below the bridge would he be if someone on the bridge was 2m into her crossing?



**Unit 9 – Geometry**

Find the volume and surface area of each of the following shapes. Round your answer to the nearest tenth.

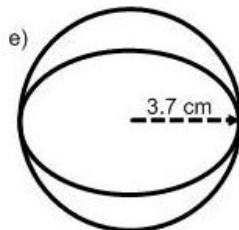
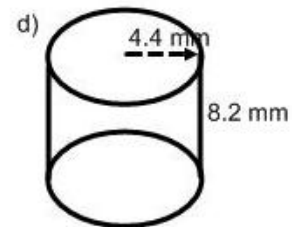
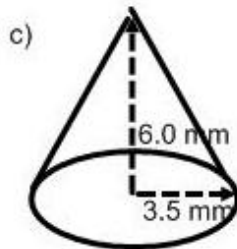
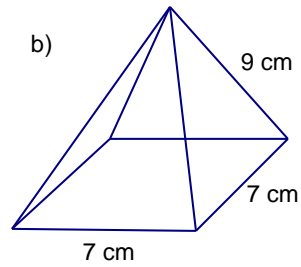
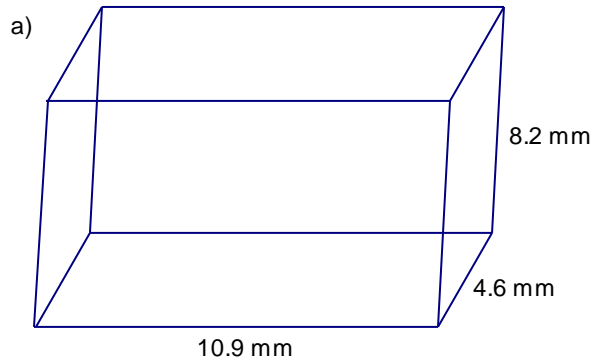

## Selected Answers:

## Unit 1: Similar Triangles

1. a) 0.625                      2. a) 4.16  
 b) 100                            b) 39.18  
 c) 32  
 d) 4                                3. 204.22  
 e) 0.75  
 f) 32                                5. 361.25  
 g) 3.2186  
 h) 36                                6. a) 139.7  
 i) 1.1811                        b) 5  
 j) 0.305  
 k) 283.5                         7. a) 12  
 l) 1.6093                        b) 2.0

## Unit 3: Linear Relations

6. a)  $y = 2x - 9$   
 b)  $y = -x + 5$   
 7. a)  $y = 7x + 2$   
 b)  $y = -3x + 9$

## Unit 5: Linear Systems

- 2.a)  $(-1, -2)$     b)  $(2, 0)$   
 4.  $(-5, 4)$   
 5.  $(5, 7)$   
 6. 41 buses, 7 vans  
 7. \$16 chips, \$6 pop  
 8. \$12 shrubs, \$12 grass

## Unit 7: Quadratic Expressions

5. a)  $x^2 + x - 6$                       8. a) 7, 2  
 6. a)  $3x(x + 2)$                       c) -7, 3  
 7. a) 128                                e) -8, 8  
 c) 125                                    9. a)  $(x - 11)(x + 11)$   
 e) 81                                    c)  $(3x - 10)(3x + 10)$   
 g) 1                                      10. a)  $(x + 2)(x + 1)$   
 i)  $1/8$                                     c)  $(x - 6)(x + 2)$

## Unit 9: Geometry

## Volume

- a)  $411.1 \text{ mm}^3$   
 b) extra careful here:  $122.5 \text{ cm}^3$   
 c)  $24.5 \text{ mm}^3$   
 d)  $158.8 \text{ mm}^3$   
 e)  $212.2 \text{ cm}^3$

## Surface Area

- a)  $354.5 \text{ mm}^2$   
 c)  $114.4 \text{ mm}^2$   
 d)  $254.3 \text{ mm}^2$   
 e)  $172.0 \text{ cm}^2$

## Unit 2: Right Angle Trig

2. a) sin                                6. a) 2.1  
 b) tan                                 b) 28.9  
 c) cos                                 c) 5.6  
 d) sin                                 d) 15.4  
    e) 52.5  
    f) 50.5  
 4. a) 0.7071  
 b) 0.8090  
 c) 3.4874                            7. 100  
    8. b) he cannot reach  
 5. a) 72                                 c) 1.7  
 b) 63                                 9. 48.2  
 c) 49                                 10. b) 0.48

## Unit 4: Linear Equations

- 1 a) 1                                    2. a)  $y = -2x + 3$   
 b) -2                                    b)  $-2/3x + 4 = y$   
 c) 2  
 d) 4                                      3. a)  $(P - b)/2 = a$   
 e) -9                                    b)  $(A - P)/Pt = r$   
 f) -3

## Unit 6: Quadratic Relations

5.  $y = -0.22(x - 5)^2 + 5.5$

## Unit 8: Quadratic Relations

5. a) 5  
 b) -2.45  
 c) -2

- b)  $165.2 \text{ cm}^2$